

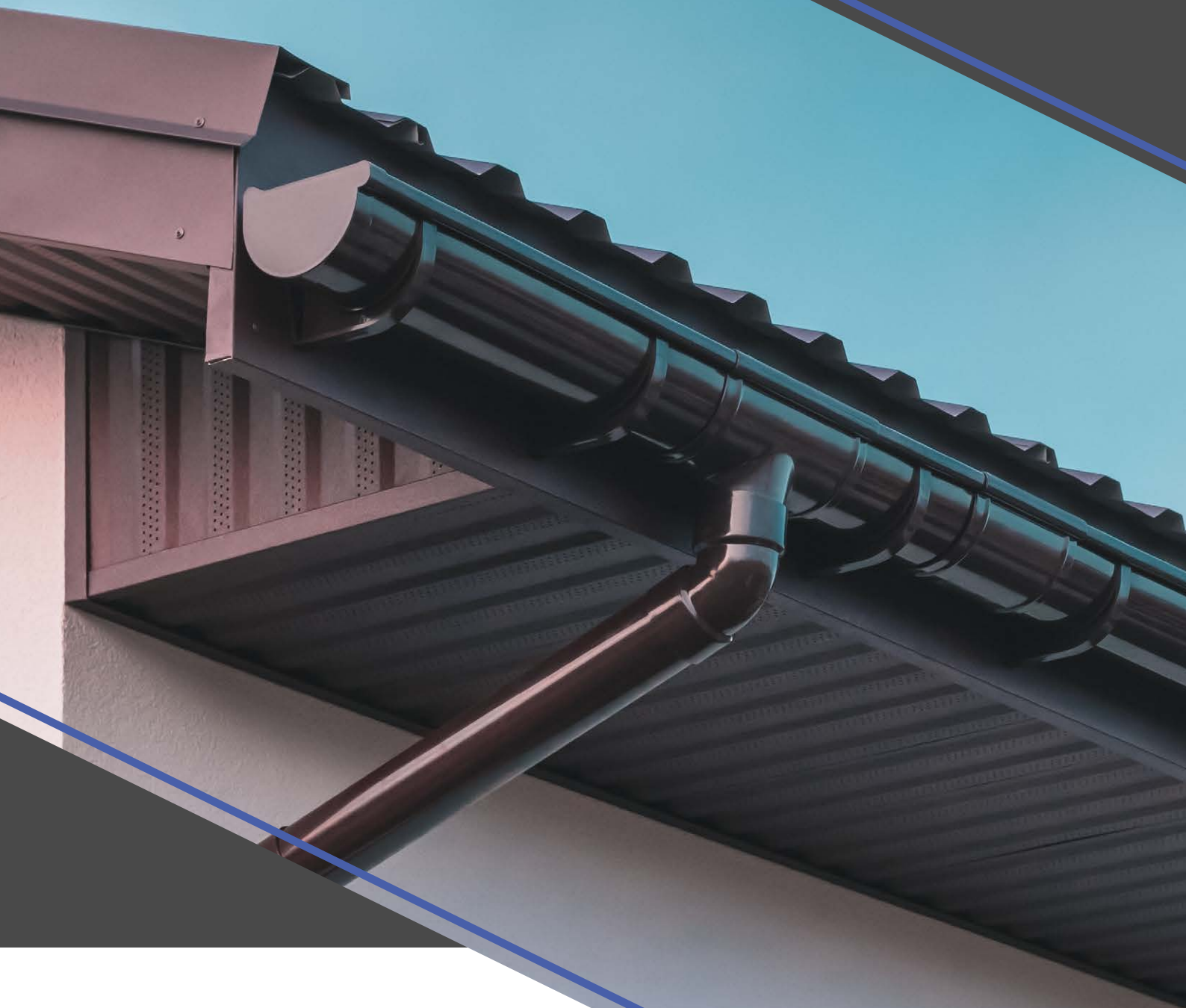

**BUDA FER**  
GYÁRTÓ ÉS KERESKEDELMI ZRT



**GUTTER SYSTEM**  
accessories

Budafer Hungary Zrt. was founded in 2017 and has been a successful company right from its very first business year.

After a structural change in 2019 we took a new, innovative direction, and now we serve our customers from our Budaörs office and Csepel depot. Our goal is to grow further and become a determining player on the domestic specialised steel products market.

To supplement steel trade in 2019 we started to broaden our scope of activity by adding the manufacturing and sale of tinsmith and metal fastening products, as well as expanding related services. By now our tower crane rental business has also become a significant participant in the local building machinery market.

Currently we serve our customers on several business areas with excellence, and we aim to fully satisfy the requirements of our future partners as well.

Service to our customers is guaranteed by our thorough knowledge of the industry and the expert professional skills of our employees.



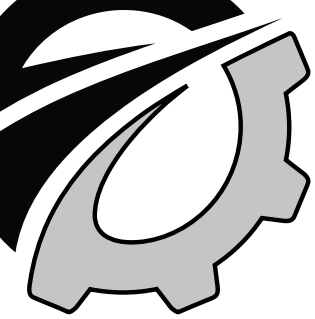

# T I N S M I T H P R O D U C T S

## **The key to the success of our tinsmith industrial activity and our vision for the future**

The manufacturing unit in Dombóvár has been operating for nearly 30 years. The main profile of the plant is the production of specialised binding bolts and rivets, the customer base of which were mainly industrial manufacturers and merchants of tinsmith products. In the meantime Budafer Hungary Zrt., as a steel merchant, has become the supplier of several manufacturers operating on this area. As a result we gradually gained better insight into the market and the driving force behind, furthermore, the increase in demand following the economic crisis has placed an ever-increasing demand and requirement on us, both in terms of increasing capacity and quality.

At the beginning of 2018 we decided to get ahead of the market via the new production technology developed by us. Previously successful manufacturers were fundamentally small businesses with so-to-say outdated technologies. Through our innovative solution coupled with state-of-the art, automated production line we are capable of high-volume and size-accurate mass production.

Our current focus, following the installation of our automated riveter and automated bending machinery, is to install another automated bending equipment in the production line, thereby increasing our output volume and activate our new improvements that are crucial for our entry to foreign markets.

What we are exceptionally proud of is that all parts of our brackets and gutter hooks are made in our Dombóvár plant, so, apart from the raw materials, we acquire no external products for the manufacturing of our own products. This grants several business benefits to us, and also provides the necessary flexibility in product development.

Our goal for 2021 is to enter new markets in addition to the German and Austrian markets to counterbalance the expected fluctuation of the domestic market, and also to spread the news about top-quality Hungarian manufacturers in additional foreign countries.





GALVANISED / POWDER COATED  
TINSMITH PRODUCTS

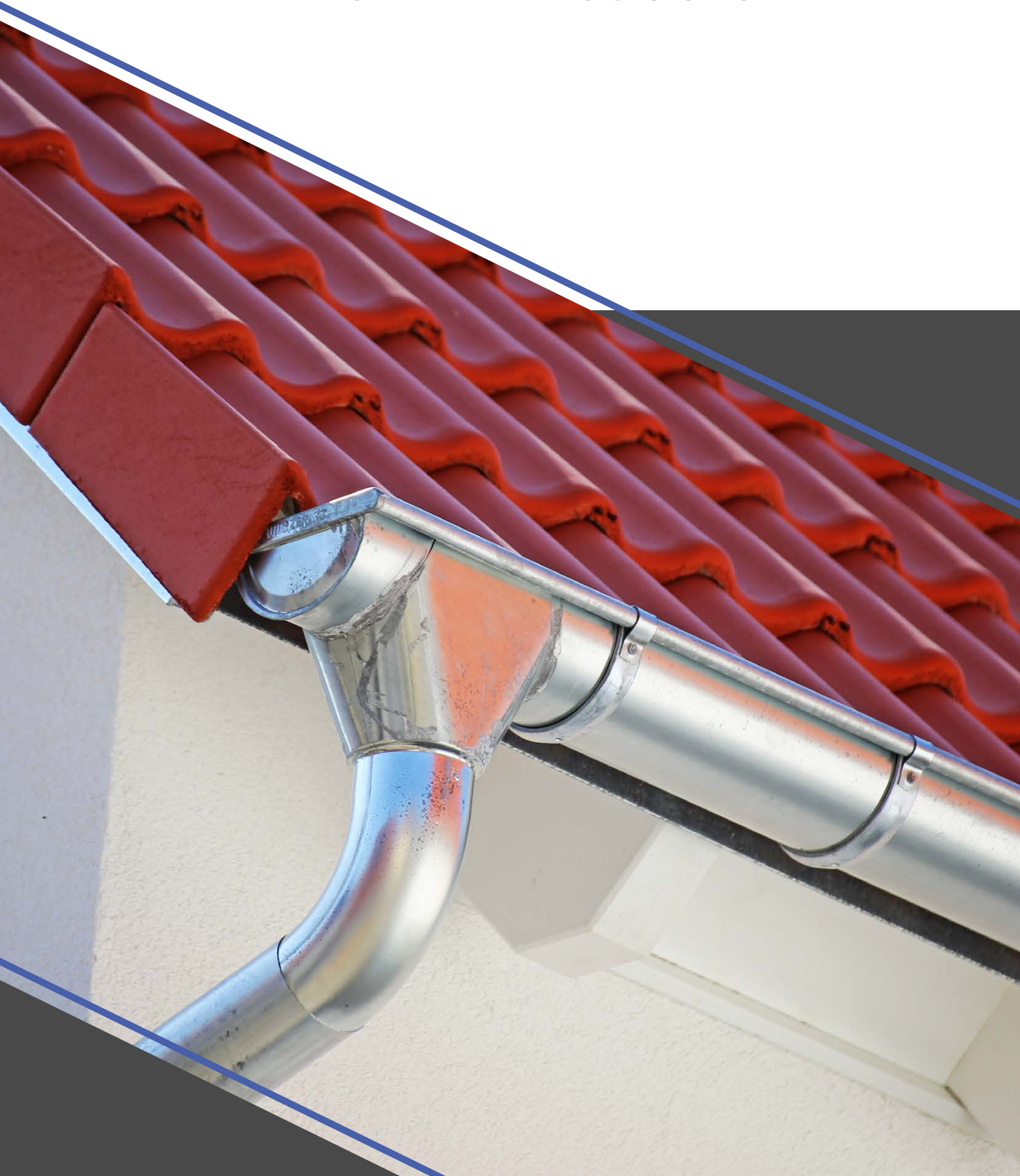

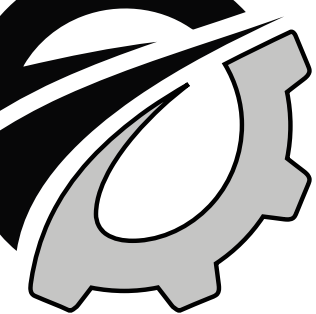

## GUTTER HOOKS

#.	Name	Length (mm)	Raw material (mm)	Colors
1.	Gutter hooks short 250-25/4	405	25x4	Hot dip galvanised, all RAL colors
2.	Gutter hooks long 250-30/5	440	30x5	Hot dip galvanised, all RAL colors
3.	Gutter hooks short 280-30/5	425	30x5	Hot dip galvanised, all RAL colors
4.	Gutter hooks long 280-30/5	480	30x5	Hot dip galvanised, all RAL colors
5.	Gutter hooks short 333-30/5	475	30x5	Hot dip galvanised, all RAL colors
6.	Gutter hooks long 333-30/5	525	30x5	Hot dip galvanised, all RAL colors
7.	Gutter hooks short 400-30/5	555	30x5	Hot dip galvanised, all RAL colors
8.	Gutter hooks long 400-30/5	615	30x5	Hot dip galvanised, all RAL colors



## BRACKETS





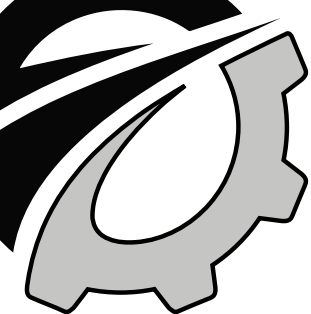

# BRACKETS

#.	Name	Diameter (mm)	Raw material (mm)	Brackets shank (mm)	Colors
1.	Brackets 80	80	30x1,5	140/200/250	Hot dip galvanised, all RAL colors
2.	Brackets 100	100	30x1,5	140/200/250	Hot dip galvanised, all RAL colors
3.	Brackets 120	120	30x1,5	140/200/250	Hot dip galvanised, all RAL colors



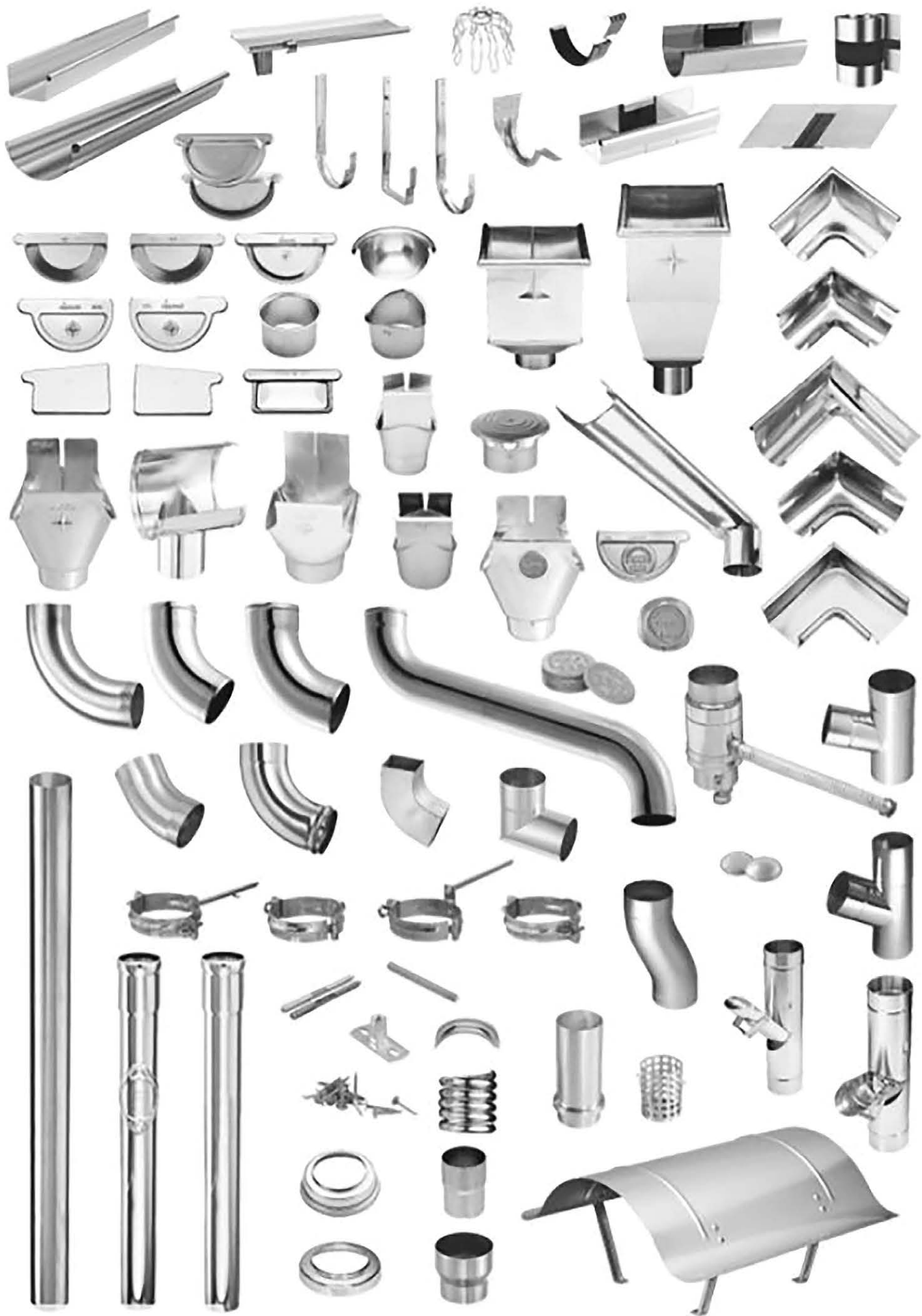



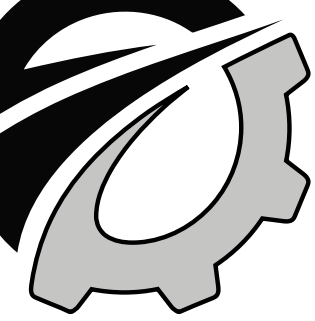

# GUTTER CALCULATOR

Use our gutter calculator to simply know, by providing the features of the roof and your own requirements, the length of gutter and drop pipes and the number of outlets and endcaps required for your home. As regards tinsmith products, in our gutter calculator you can choose from among premium and standard quality, galvanised or other, tinted gutter systems. In case you need assistance with the purchase, please, contact us for a quote; our colleagues are at your service with our tinsmith products!

1. Select the desired building type and enter the dimensions of the roof.

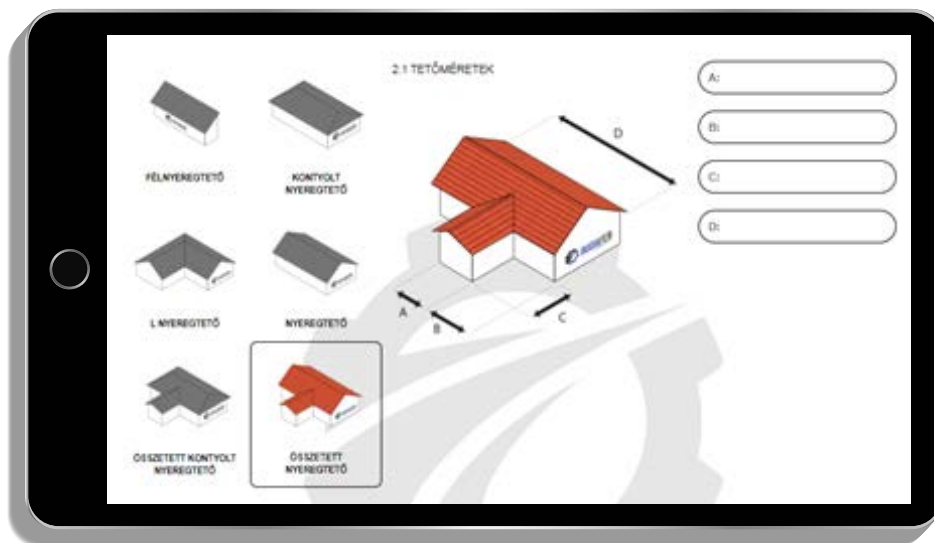

2. Enter all other required parameters and click Calculate.

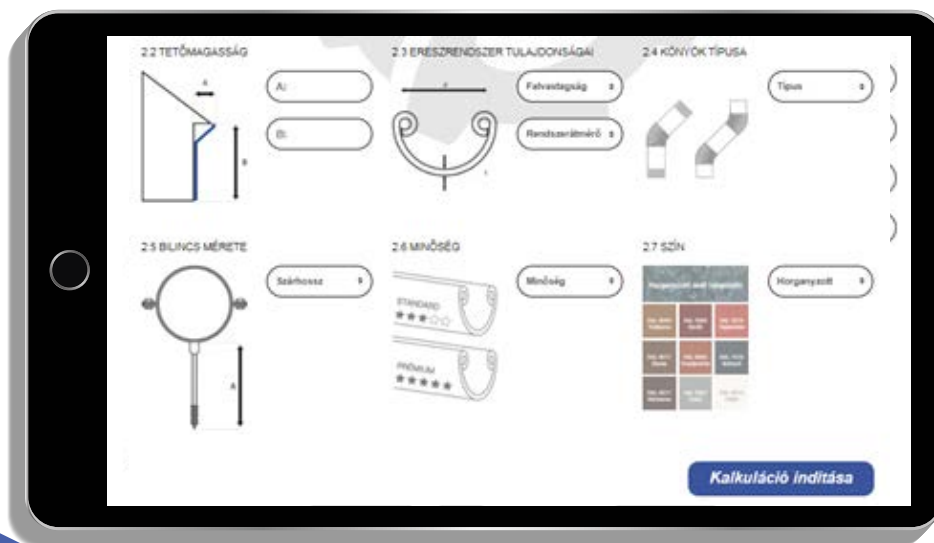

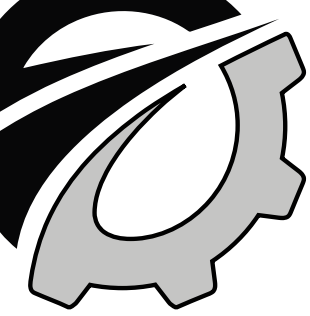

3. See the result of the calculation and contact us for a quote.

A MEGADOTT PARAMÉTEREK ALAPJÁN ÖNNEK AZ ALÁBBIKRA VAN SZÜKSÉGE:

MEGNEVEZÉS	MENNYISÉG	MÉRTÉKEGYSÉG
Csatorna	84	m
Kampó	113	db
Zárt vég	0	db
Sarok	2	db
Zárt vég kifolyóval	6	db
Betorkolló	1	db
Lefolyó	35	m
Könyök	7	db
Bilincs	35	db



## Scan

the QR-code and you are ready to start the calculation. By specifying some features of the roof it takes only a few of steps to get the list of the items necessary for building the gutter system.

Calculate with us!



Contact:  
Budafer Gyártó és Kereskedelmi Zrt.  
Zsolt Sipos  
General Manager  
+36 30 696 5718  
[siposzsolt@budafer.hu](mailto:siposzsolt@budafer.hu)